

IWATSU

Soft magnetic materials' property tests



SY-8218 10Hz to 10MHz
SY-8219 10Hz to 1MHz

**Highly accurate
automatic measurement
at high frequency**

B-H analyzer

Wide temperature range scanner system SY-330



Scanner system SY-321A/320A



DC bias test system SY-960, 961, 962



Single sheet test system SY-956

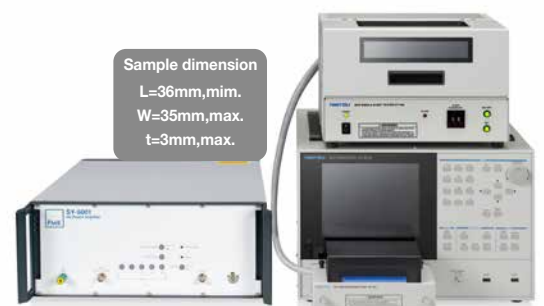

Precise magnetic property measurement at high frequencies

Precise and accurate core loss measurement

Iwatsu's B-H analyzers which hiring CROSS-POWER method (IEC62044-3) enable precise and highly accurate measurement embedded minimized phase error integration on frequency spectrum with current detecting resistors and compensation on detecting circuit with full compensation on amplitude and phase characteristics. Third generation models are available now to contribute leading-edge development on future power management.

SY-810 Remote control software



SY-5001 amplifier

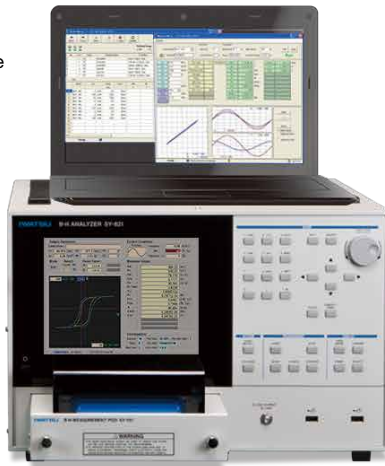

SY-8219 B-H analyzer



SY-320A Temperature scanner system

- Wide band frequency range from 10Hz to 10MHz (SY-8218)
- 41 pcs., max. specimen for temperature range of -30°C to 150°C automatic scanner system (SY-321A)
- Voltage : $\pm 150V$, max. / Current : $\pm 6A$, max. DC to 3MHz High power amplifier (SY-5001)
- 36mm(L),min. 35mm(W),max. single sheet test (SY-956)
- DC30A, max. DC-bias superposition test (SY-960, 961, 962)

B-H analyzer



SY-8218 / SY-8219

Wide temperature scanner

Autovehicle standard:
AEC-QA200 Grade0



SY-330

Temp. scanner system



SY-320A / SY-321A

DC biasing system

AC blocker SY-962



DC bias source SY-961

DC bias tester SY-960

Single sheet tester



SY-956

Amplifier







SY-5002

HSA4101-W

SY-5001

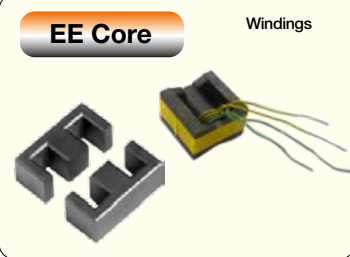
Various types of soft magnetic material property test

Soft Materials Ferrite Permalloy Amorphous Si steel sheet Powder Core	Shape Troidal EE core EI core Sheet Powder	Troidal Windings 	Powder  SY-513
		EE Core Windings 	Sheet 

Fully automatic test

Sample parameters (Le: magnetic pass, Ae: cross section, N1 and N2, etc.) and test conditions(Frequency, Hm, Bm, V2m or I1m) inputs enable obtaining BH hysteresis curve and magnetic properties in value automatically.

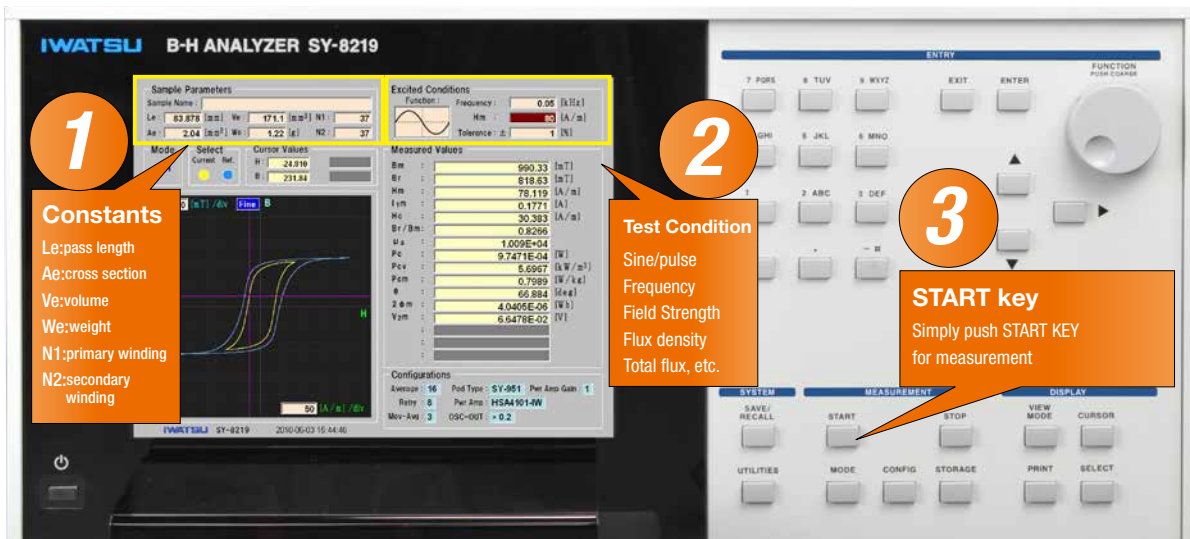

1

Constants

- Le:pass length
- Ae:cross section
- Ve:volume
- We:weight
- N1:primary winding
- N2:secondary winding

2

Test Condition

- Sine/pulse
- Frequency
- Field Strength
- Flux density
- Total flux, etc.

3

START key

Simply push START KEY for measurement

Fully automatic test with options

SY-810 Remote control software is Temperature scanner system, Single sheet test system and DC biasing system.

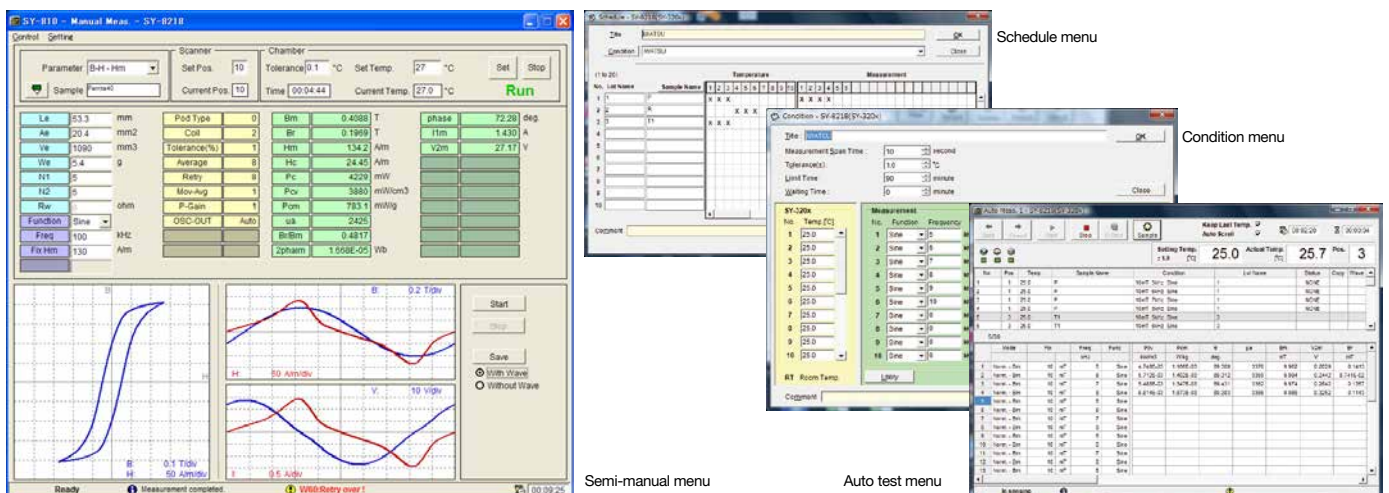

Schedule menu

Condition menu

Semi-manual menu

Auto test menu

Precise test in higher frequency

B-H Analyzers

SY-8218 10Hz ~ 10MHz

SY-8219 10Hz ~ 1MHz



SY-8218



[Test example]
Measurement POD
(without POD cover)

- Test Freq. 10Hz to 10MHz(SY-8218), 10Hz to 1MHz(SY-8219)
- Signal waveform SINE or PULSE(10Hz to 1MHz)
- Max. Input current ±6A
- Max. Input voltage ±200V
- Excitation method Automatic excitation (Target : Hm, Bm, I1m or V2m)
Automatically degaussing after excitation to avoid magnetization

Measurement method	CROSS-POWER method (Compatible to IEC62044-3 standard)	
Measurement item (Symbol)	Max. Magnetic flux density(Bm), Residual magnetic flux density(Br), Max. Magnetic field strength(Hm), Coersive force(Hc), Rectangular ratio(Br/Bm), Relative amplitude permeability(μ_a), Core loss(Pc, Pcv, Pcm), Primary excitation current(I1m), Secondary induced voltage(V2m), Phase(θ), Total magnetic flux linkage($2\phi_m$), Apparent power(VA), Impedance permeability(μ_z), Complex permeability(μ' , μ''), Loss coefficient($\tan \delta$), Inductance(L), Resistance(R), Impedance(Z), Quality factor(Q), Total harmonic distortion(THD)	
Waveform display	B-H curve, Primary current, Secondary voltage, Magnetic field, Flux density	
Test Frequency	SINE	10Hz~10MHz(SY-8218), 10Hz~1MHz(SY-8219)
	PULSE	10Hz~1MHz(Duty50% fixed)
Magnetic field detection	Voltage detection on non-inductive shunt, max. current at ±6A	
Flux density detection	Voltage at detection coil, max voltage at ±200V	
Disitizer	Resolution : 16bits (8192points/cycle)	
Coil method	Two winding method or single winding method selectable	
Display	8.4 inch TFT-LCD SVGA 800 x 600pixel	
Weight, Dimensions	Approx. 12.5kg, Approx. 420W x 266H x 480D(mm)	
External output	USB(storage)	
Accessories	POD cover, SY-504 : AC coupler, Power amplifier cable (BNC-BNC), OSC Cable(BNC-SMA), Power cable, Users guide, Instruction manual(CD-ROM)	

Hi-Speed Bipolar Power Supply (Power Amplifier)

Wide frequency bandwidth Hi-power Bipolar Power Supply

Bipolar power amplifier for B-H analyzers

	Frequency Bandwidth	Max. output current	Max. output voltage
SY-5001	3MHz	±6Apeak	±150Vpeak
SY-5002	3MHz	±6Apeak	±75Vpeak
HSA4101-IW	10MHz	±1Apeak	±71Vpeak



SY-5001 (PMK GmbH)



SY-5002 (PMK GmbH)



HSA4101-IW

Model	SY-5001
Frequency	DC - 3MHz
Gain	1, 5, 10, 30, 60 ± 2% (±100ppm/°C)
Output Voltage	HIGH mode ±150Vpeak (f<750kHz)
	LOW mode ±75Vpeak (f<1.4MHz)
Output Current	HIGH mode ±5Apeak (f>10Hz)
	LOW mode ±6Apeak (f>10Hz)
Output Impedance	30mΩ + 0.33μH
Size (mm)/Weight	Approx. 449Wx178Hx435.5D/19kg

Model	SY-5002
Frequency	DC - 3MHz
Gain	30 ± 1% (±100ppm/°C)
Output Voltage	HIGH mode ±75Vpeak (f<900kHz)
	LOW mode ±37.5Vpeak (f<1.8MHz)
Output Current	HIGH mode ±5Apeak (f>10Hz)
	LOW mode ±6Apeak (f>10Hz)
Output Impedance	50mΩ + 0.30μH
Size (mm)/Weight	Approx. 449Wx133Hx435.5D/14kg

Model	HSA4101-IW	
Frequency	DC~10MHz	
Output current	±71Vpeak	
Output voltage	±1Apeak	
Output power	50VA	
Power supply	Frequency	50/60Hz
	Voltage range	AC100/115/200/230V selectable
	Power consumption	700VA (400W)
Size (mm)/Weight	Approx. 220Wx177Hx440D/7.8kg	

Wide temp. range scanner SY-330, Scanner system SY-320A / 321A

Temp. range from **-55°C to +180°C**
 Large size samples : max. 4pcs.

Wide temperature scanner

SY-330 4pcs.

Autovehicle std. AEC-Q200 Grade0 compatible





Temp. range from **-30°C to +150°C**
 Automatic test for max. 41pcs. samples

Temperature scanner system

SY-320A 20pcs. / **SY-321A** 41pcs.



		SY-330
Chamber	Power supply	AC200V 3ϕ 3W 50/60Hz
	Max. current	14A, max.
	Temp. range	-55°C~+180°C
Scanner Unit	Power supply	AC 100V to AC240V 50/60Hz
	Max. power	21VA, max.
	Frequency range	10Hz~3MHz(SY-8218) 10Hz~1MHz(SY-8219)
	Sample	4pcs., max.
	Max. current	±6A
	Max. voltage	±200V
Size(mm), Weight		1,023W x 607L x 1,200H, Approx. 190kg
Accessories		Chamber cable(SY-912), RS232C cable, Pushing jig(SY-512), Power cable, Manual

Options	
GPIO I/F Model NI GPIB-USB-HS+  ※ NATIONAL INSTRUMENTS Corp.	
Serial I/F Model NI USB-232  ※ NATIONAL INSTRUMENTS Corp.	

		SY-320A	SY-321A
Chamber	Power supply	AC100V 50/60Hz	
	Max. current	12.5A, max.	21.0A, max.
	Temp. range	-30°C~+150°C	
Scanner Unit	Power supply	AC 100V to AC120V 50/60Hz	
	Max. power	28VA, max.	
	Frequency range	10Hz~5MHz(SY-8218) 10Hz~1MHz(SY-8219)	
	Sample	20pcs., max.	41pcs., max.
	Max. current	±6A	
	Max. voltage	±200V	
Size(mm), Weight		543W x 695L x 620H Approx. 85kg	640W x 920L x 660H Approx. 135kg
Accessories		Chamber cable(SY-910), GPIB cable(1m), Power cable, Instruction manual, Turntable SY-510 (for SY-320A) or Turntable SY-511 (for SY-321A)	

Remote control system configuration

Remote control system with Wide temp. range scanner : SY-330

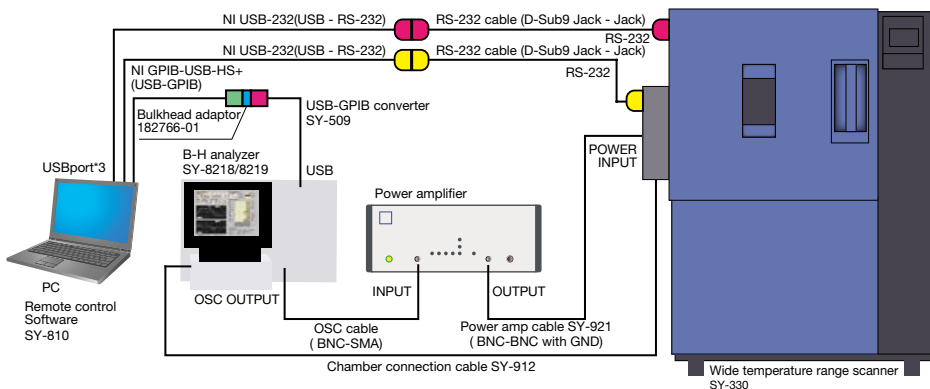

Remote control software : SY-810

※ See page8 for details

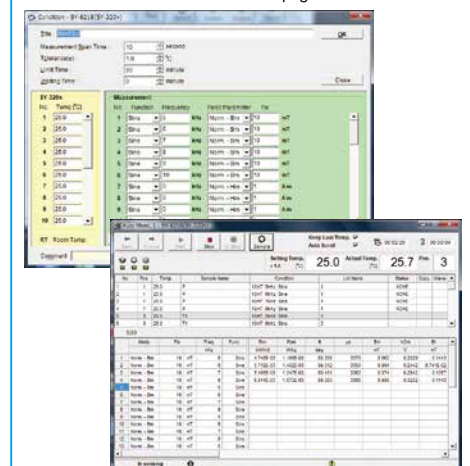

Remote control system with scanner system : SY-320A / SY-321A

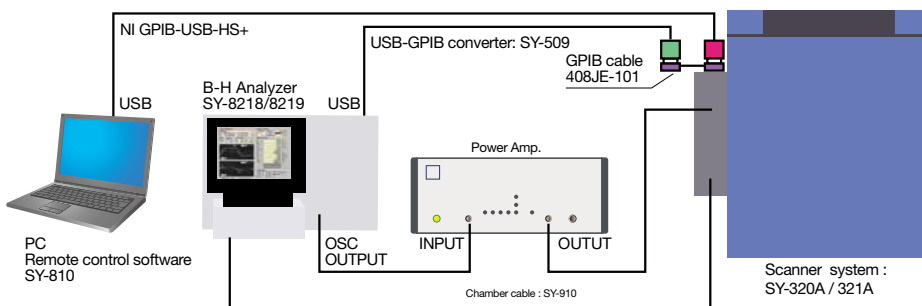

Optional consumable parts (for SY-320A/321A)

Spare turntable(for setting samples)
 SY-510 (for SY-320A)
 SY-511 (for SY-321A)



Spare contact pin set
 SY-512 (for SY-320A/321A)



AC BH analysis on single sheet / ribbon

Single sheet test system SY-956



- Test frequency : 10Hz to 20kHz
- Max. Magnetic field strength : 10,000A/m
- Sample size : 36mm(L) or longer, 35mm(W)max., 3mm(Thickness)max.
- Vertical single yoke test method
- Core loss in yoke cancelling compensation (Patent pending : No. 5885646)
- Controlable pressing pressure on specimen for test reproductivity

Test method	Vertical single yoke single sheet magnetic property test method (IEC 60404-3 compatible)(with yoke core loss compensation)
Max. Magnetic field	Approx. 10,000A/m(with excitation current at 5A)
Test frequency	SINE : 10Hz to 20kHz
Available sample size	36mm(L) or longer, 35mm(W)max., 3mm(Thickness) max.
Max. excitation current	±6A
Max. voltage	±200V
Power supply	AC100V to AC240V, 50Hz/60Hz, 27VA max.
Temp. range	+18°C to +28°C for test specification guarantee
Size(mm), Weight	Approx. 330W x 200H x 320D, Approx. 8.5kg
Accessories	Connection cable(SY-957), B coil(2types), Terminal screws, Pincer, Blowing brush, Accessory case, Power cable, Instruction manual



B coil for voltage detection

Model	B coil 01	B coil 02
Outer look		
Sample size	Max. 1mm(Thickness), Max. 10mm(W), 35turns	Max. 1mm(Thickness), Max. 30mm(W), 100turns

※ B coil can be wound for preferable turns.

Magnetic sheet can be varied of it's magnetic characteristics according to it's shape and before/after shaping process.

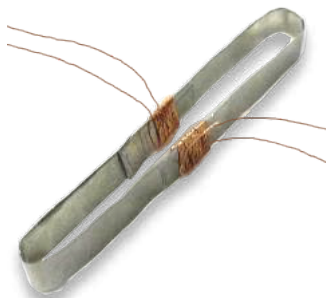

Example of Permalloy

Hc	Circle = Oval
Br	Circle < Oval
Bs	Circle < Oval
Core loss	Circle < Oval

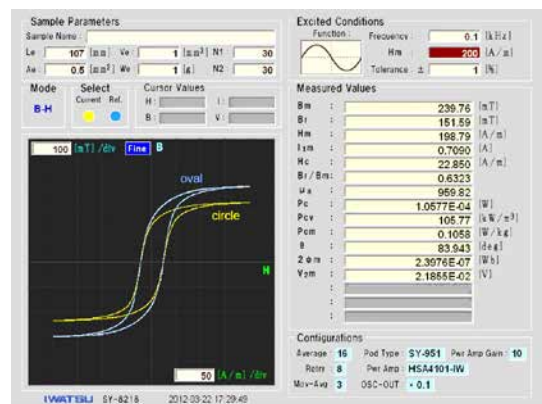

LF AC coupler SY-514

Best to eliminate offset voltage of power amplifier
SY-514 enables measurement with cut-off frequency at 300Hz while SY-504 (std. accessory) offers cut-off frequency at 10kHz.



BNC cable(0.6m)

Cut-off freq. : Approx. 300Hz, Max. input voltage : ±200V
Max. input current : ±6A, BNC cable (0.6m/std. accessory)

10kHz AC coupler SY-504



※ Standard accessory for BH analyzer

Troid shape case SY-513

Best for sheet troids and/or powder material measurement

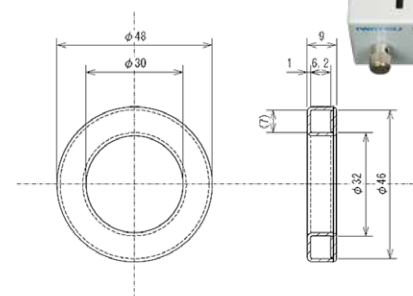

AC BH Analysis with DC biasing

DC bias tester
SY-960,961,962

- Max. DC biasing 30A
- Max. AC ripple ±6A
- Test freq.(SINE) 10kHz~3MHz
(Lowest frequency can be 10kHz or higher according to inductance value of specimen)
- Test freq. (PULSE) 10kHz~1MHz (Duty10%~90%)

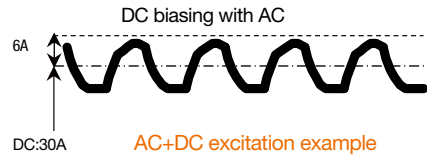
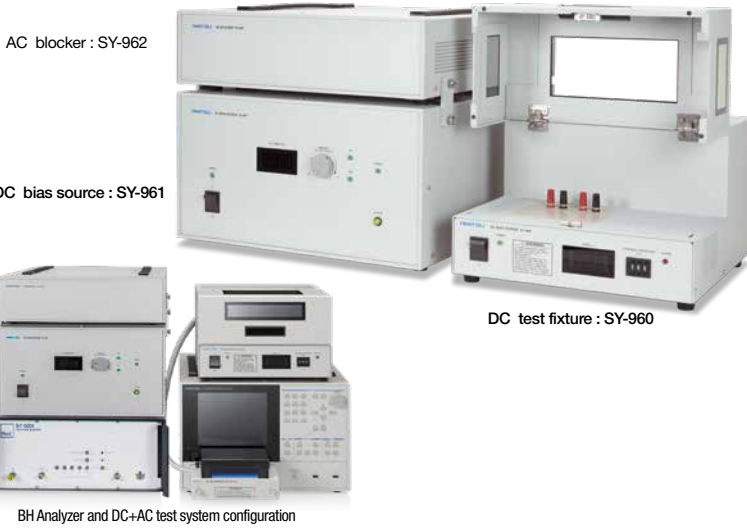

PULSE signal excitation (triangle signal current on specimen) or SINE+DC biasing excitation is available.

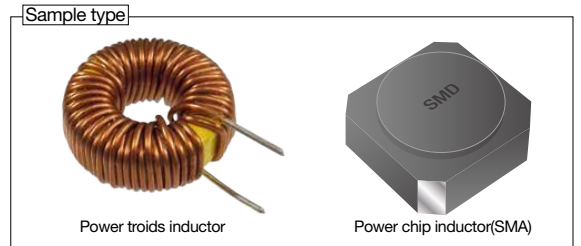

Example of chip inductor test (Chopper excitation)

Magnetic characteristics by increasing DC bias at fixed ΔH

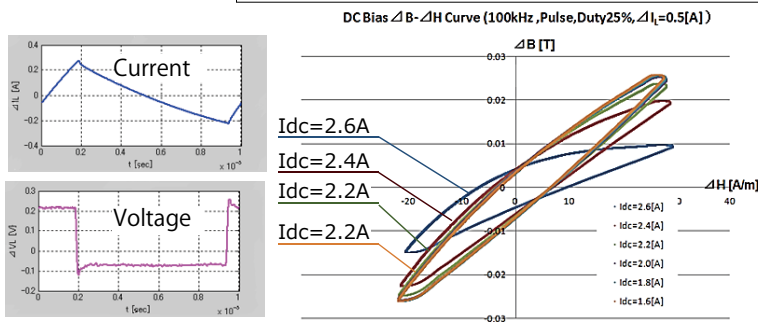

DC bias vs ΔP_c

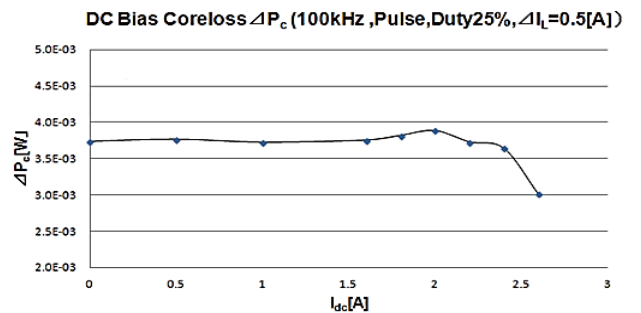

Examples of hysteresis curves of DC biasing. AC+DC excitation shows changes of hysteresis curve following DC bias level.

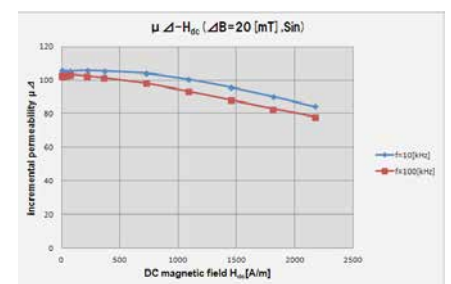
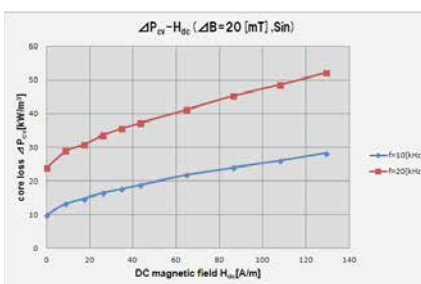
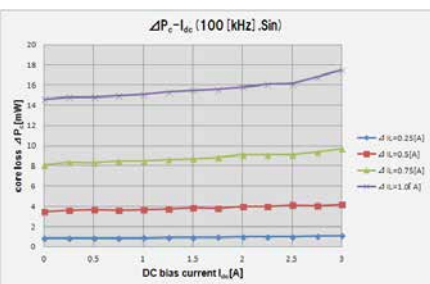
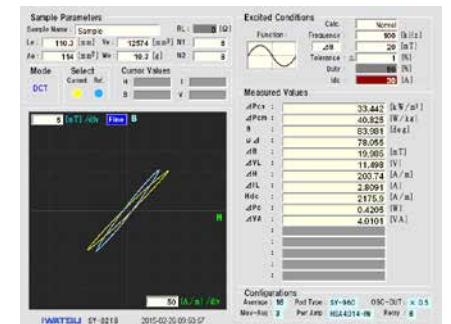
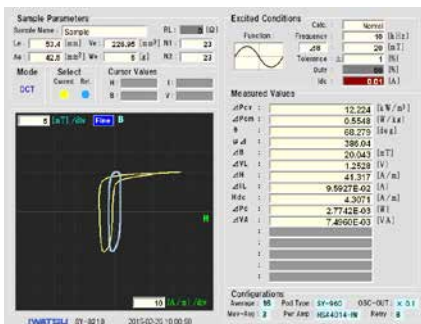
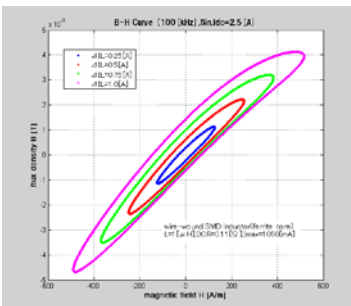

Automation with various test conditions

BH Analyzer remote control software for PC

SY-810

- Temperature : 20 kinds, Excitation : 40 kinds of conditions can be set.
- Max. 800 kinds of test conditions are available for each sample.
- Test data (waveform at CSV basis) and display hardcopy (JPEG, PNG) are available.
- SY-810 can control wide temp. range scanner(SY-330), scanner system(SY-320A/SY-321A), DC bias tester and single sheet test system for automatic tests.

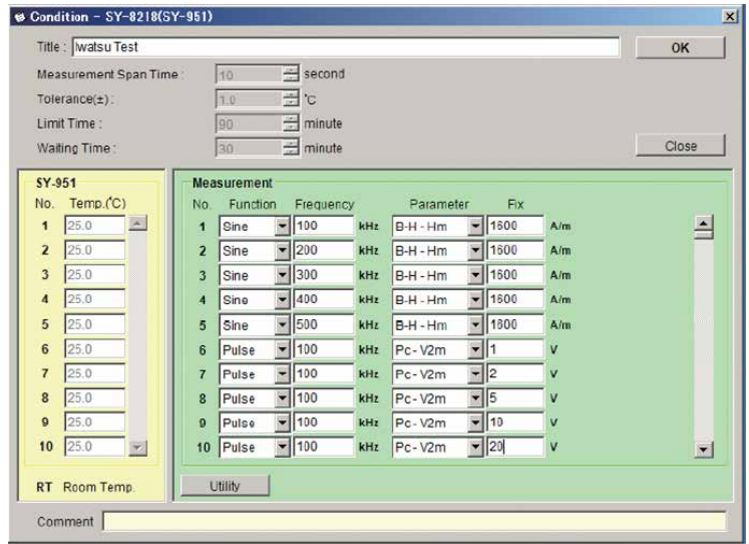

SY-810 contains CD (software & operation manual at PDF), GP-IB converter SY-509, Bulkhead adaptor 182766-01 and software license agreement OS: Windows Vista SP2, Windows7 32bit/64bit, Windows8 32bit/64bit, Windows10 32bit/64bit .NET Framework(packed), CPU Pentium133M or above, Memory at 64Mbyte or more, Display resolution at 1024x768 or above, USB port x3
 ※ Contact our sales for the most recommended system configurations.
 ※ NI GPIB-USB-HS+ (NATIONAL INSTRUMENTS) is required for PC interface with SY-8218/SY-8219. PC is not included with this system and supplied by customer.

Built-in software function for BH Analyzer (Optional)

Continuous test function SY-811

Time-tendency property test can be performed at continuous excitation.

- Test timeframe at 99,999minutes(Approx. 70days), max. 60second/test
- 2 kinds of properties can be monitored on display and extracted to memory.
- Measurement item can be changed during test.
- Comparison between Reference and test result on the same display.
- Test data at CSV and display hardcopy at JPG/PNG are available.

※ Built-in option for BH analyzer
 ※ Implementation of SY-811 on BH analyzers(SY-8218/SY-8219) at the customer end will be returned to our factory for installation and inspection.

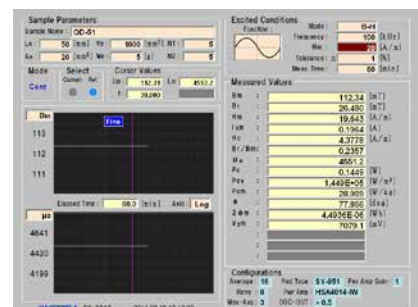

※ The products shown in this catalogue are current models at the date of publication. Design and specification are subject to change without notice for improvement.
 ※ All enterprises including National Instruments and Microsoft, etc. and product names mentioned are trademarks or registered trademarks of the respective owners.
 ※ Some of the products are Regulated Products subject to the ForeignExchange and Foreign Trade Control Law of Japan. Export should not be allowed without appropriate governmental authorization. Please ask our sales office whether the product concerned is a Regulated Product(s).